

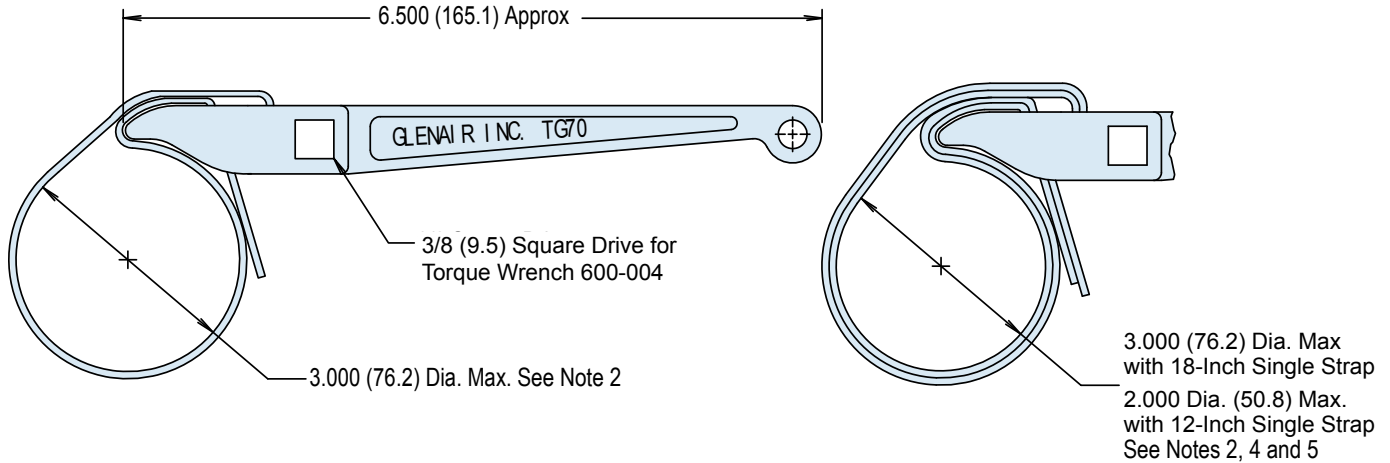

TG70 Connector Strap Wrench with 3/8" Square Drive

Connector strap wrench



Basic Part Number	Torque Wrench (Omit for None)
TG70 - 1 - 18	

Strap Length in Inches (See Notes 2 and 4)
 Lengths Available: 12, 18, 24 and 36-Inch Only
 Standard length is 12 Inches,
 Omit Dash Number for Standard

- ### APPLICATION NOTES
- These wrenches are made of the following materials:
 Wrench Handle - Aluminum Alloy/Nickel Plate.
 Wedge - Stainless Steel/Passivated.
 Strap - Impregnated Fabric. Straps are 1/2 inch (12.7) in width.
 - Replacement straps are available. Specify part number G70515-xx for 12, 18, 24 or 36-inch strap. 24 and 36 inch for double wrap.
 - Metric dimensions (mm) are indicated in parentheses.
 - Double wrap as shown for heavy duty range.
 - Not recommended for composite coupling nuts (use 600-091 or 600-157).

VARIANCE CHART

TG-70 Strap Wrench Used with Glenair Torque Wrenches

Accessory Shell Size	Recommended Installation Torque			
	Light/Medium Duty ± 5 Inch Pounds		Heavy Duty ± 5 Inch Pounds	
	TG70 Torque	Part Torque	TG70 Torque	Part Torque
08/09	28	35	45	60
10/11	28	35	70	80
12/13	30	40	75	110 [80]
14/15	30	40	75	120 [80]
16/17	30	40	75	120 [80]
18/19	30	40	75	120 [80]
20/21	75	80	95	140 [100]
22/23	75	80	120*	140
24/25	75	80	120*	140
28			135*	150
32			150*	150
36			150*	150

* TG70 Not Recommended For Values of 120 Inch Lbs. or Greater.

- ### VARIANCE CHART NOTES
- Recommended installation torque is approximately 80% of MIL-C-85049 accessory thread strength values.
 - Heavy duty installation torque values may be difficult to attain with the TG70 Strap Wrench; the values shown in brackets [] are the maximum attainable with the TG70 Strap Wrench using a single wrap.
 - Glenair recommends using 600 series torque tools whenever possible. When torque loading exceeds 75 inch pounds, or to attain the heavy duty torque values shown, a double wrap strap provides suitable friction to achieve torque values.
 - Glenair recommends that heavy duty torque values be directly read through the connector shell body with the use of 600-005 connectors holding tools.