

BLRT

AUTOMATIC BOND, LOOP & JOINT RESISTANCE TEST SYSTEM



**Approved by The Boeing Company as an
alternative to the LRT Loop Resistance Tester**

WHAT IS ELECTRICAL BOND TESTING?

The electrical bonding on an aircraft protects the aircraft and passengers by limiting the effects of lightning strikes, stray currents, HIRF and EMC. The integrity of bonding circuits is critical to ensure they perform reliably to ensure normal and safe operation of the aircraft control and communication systems.

BOND TEST

Measures the electrical resistance between two metallic elements, typically between a bracket and structure. The BLRT uses the 4-wire (Kelvin) resistance measurement to ensure micro-ohm accuracy.

LOOP TEST

Here, several metallic elements and equipment are connected to create a loop of parallel resistance. The loop is typically made up of cable shields and bonding straps. The loop test makes use of specially designed test method, using a pair of clamps to inject and detect current flowing through the loop. The BLRT controls the flowing current and frequency, combines this with the known voltage fed back from the internal power source, and automatically carries out a phase correction to accurately report the loop resistance.

JOINT TEST

The ground loop is made up of several elements such as shield, backshell, connector, equipment and structure. The joint resistance between these elements is critical in determining the total loop resistance. If a loop resistance is high, it is likely due to a single joint being loose or damaged, hence showing high resistance. While the BLRT loop clamps are injecting a known current through the ground loop, joint probes are used to measure the volt drop across specific joints; the volt drop is then phase corrected, and the joint resistance reported.

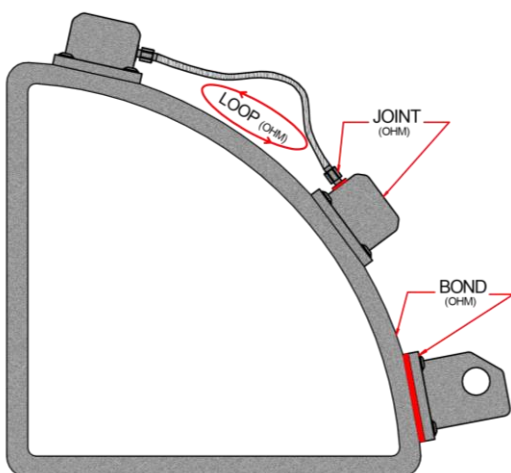

THE BLRT PERFORMS SIMPLE, RAPID & AUTOMATIC TEST AND MEASUREMENT OF:

- ✓ Bond resistance between structural elements
- ✓ Loop resistance and integrity of cable shields
- ✓ Loop resistance and integrity of bonding straps
- ✓ Joint resistance diagnostics



BLRT FEATURES & BENEFITS

LIGHTWEIGHT AND ROBUST

- ✓ Single operator use
- ✓ Battery powered and truly portable
- ✓ Weight <7kg
- ✓ Size 35cm x 30cm x 15cm

AUTOMATIC

- ✓ Integrated computer complete with MK BLRT software
- ✓ Automated test process, saving time and gaining efficiency
- ✓ Paperless process
- ✓ On screen graphical operator guidance
- ✓ Simple touchscreen control
- ✓ User login and access control
- ✓ Automatic pass and fail of measured value
- ✓ Automatic logging and upload of test results
- ✓ Guarantees traceability by user, UUT, measured result

ACTIVE PROBES AND CLAMPS

- ✓ Push button control enables full test control from the probes and loop clamps
- ✓ LED pass fail indication on probes and loop clamps improves test efficiency
- ✓ Integrated lights on probes for testing in dark areas
- ✓ Various probe and clamp formats and sizes available

RELIABLE AND ACCURATE

- ✓ Integrated self test and validation toolset
- ✓ Automatically validates system performance during test and after clamp or probe change

FEATURES	BLRT	LRT
Operators	✓ Single	× 2 operators required
Calibration	✓ Can be carried out by user in typically 30 minutes	× Return to base – typical turnaround is 2 months
Weight	✓ 7kg / 15.5lbs	× 17kg / 37.5lbs
Batteries	✓ Hot swap batteries – batteries can be replaced whilst unit is in use	× Low battery power affects accuracy of results. Tool can't be used whilst battery is charging
Typical leadtime	✓ Available from stock	× 16-20 weeks

MAIN FEATURES			
✓ Tough polypropylene enclosure	✓ Carrying handle and optional harness	✓ USB port (when data adapter fitted)	
✓ Flip-off protective lid, with self-test fixture	✓ Soft-start current source prevents arcing	✓ Network port (when data adapter fitted)	
✓ LCD 10.4" touchscreen integrated monitor	✓ On-screen instructions	✓ Active probes & clamps	
✓ Smart Li-Ion "hot-swap" batteries	✓ Auto and manual modes	✓ Pass fail status indication on probes & clamps	
✓ Lightweight	✓ Wireless data upload & download	✓ Wide range of custom probes available	
BOND TEST MEASUREMENT (DC) – OPTIONAL – ONLY APPLIES WHEN FITTED			
Current (DC)	up to 10A (10% accuracy)	Resistance resolution	0.1mΩ
Resistance range	0.2mΩ to 2mΩ	Resistance accuracy	±(1% of reading ±0.2mΩ) @ 10A
LOOP TEST MEASUREMENT			
Mode	Range 1	Range 2	Range 3
Frequency	1Arms (constant current)	1Arms (constant current)	0.2Vrms (constant voltage)
Resistance range	1kHz	1kHz	1kHz
Resistance resolution	1mΩ to 50mΩ	51mΩ to 200mΩ	201mΩ to 2000mΩ
Resistance accuracy	0.1mΩ	0.1mΩ	0.1mΩ
	±(2% of reading +0.5mΩ)	±(2% of reading +0.5mΩ)	±(5% of reading +0.5mΩ)
			±(10% of reading +0.5mΩ)
JOINT TEST MEASUREMENT			
Mode	Range 1	Range 2	Range 3
Frequency	1Arms (constant current)	1Arms (constant current)	0.2Vrms (constant voltage)
Applied loop resistance range	1kHz	1kHz	1kHz
Joint resistance range	1mΩ to 50mΩ	51mΩ to 200mΩ	201mΩ to 2000mΩ
	0.5mΩ to 50mΩ	0.05mΩ* (@51mΩ loop) to 200mΩ	0.50mΩ* (@201mΩ loop) to 2000mΩ
Resistance resolution	0.01mΩ	0.01mΩ	0.1mΩ
Resistance accuracy	±(5% of reading +0.5mΩ)	±(5% of reading +0.25 of loop)	±(5% of reading +0.25% of loop)
			±(10% of reading +0.25% of loop)
* To determine lowest measurable joint resistance for a given loop use: Joint(low)=Loop resistance x percentage shown.			
LOW JOINT INDICATION			
Mode	Autoranging (max 1Arms)	Joint resistance range	Up to 0.05mΩ
Frequency	200Hz	Resistance resolution	n/a
Applied loop resistance range	0.5mΩ to 40mΩ	Resistance accuracy	System reports "<0.05mΩ" for measurable joints below 0.05mΩ

Support and further information

MK Test System solutions combine powerful and flexible capability with a global sales and support network to provide our customers with the most complete solution available in the testing industry.



MK HQ & regional offices
(UK, USA, Hong Kong)



MK distributors offering
technical and sales support

Head Office – UK

MK Test Systems Ltd
ATE House, Westpark 26
Chelston, Wellington
United Kingdom
TA21 9AD

Regional Office – Americas

MK Test Systems Americas, Inc.
22102 Pepper Road
Lake Barrington
Illinois 60010
USA

Regional Office – Asia

MK Test Systems Ltd (Asia)
Emerald Villa
328 Mong Tseng Tsuen
Yuen Long, NT
Hong Kong